

Drop & Lock is one of many solutions from Zahner providing quick, efficient and cost-effective installation of various wall systems. The solution includes structural mullions, anchor systems for attaching to walls, ceilings or structure, and you choice of Zahner wall system. The Drop & Lock system is compatible with various metals and treatments, including Zahner's proprietary Surfaces. All components are CNC cut and ready for installation.

Applications:

- Interior and exterior installations
- New construction, retrofit, or add-on
- This solution accomodates a variety of Zahner's rainscreen, dry seal and vented wall systems.

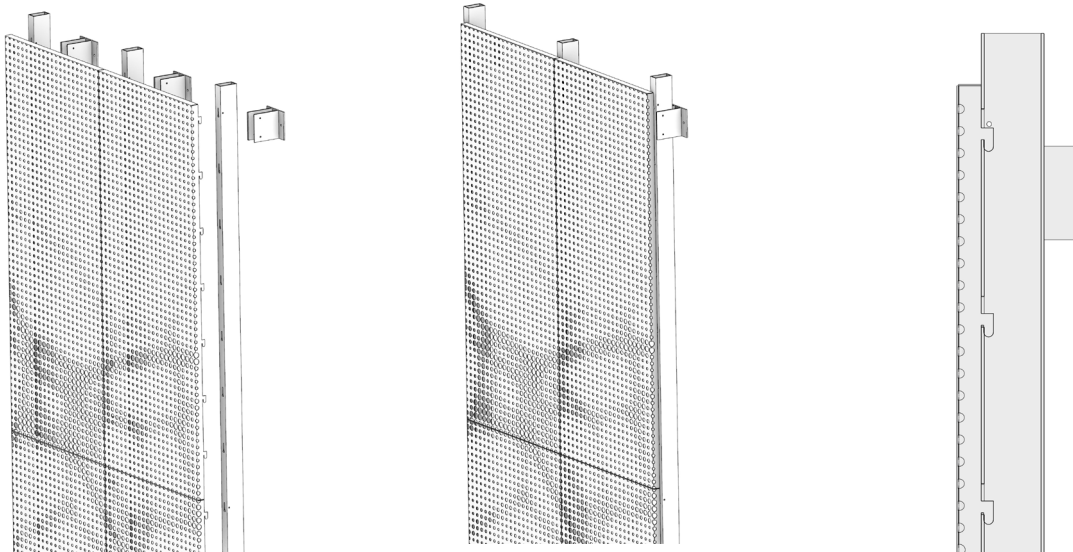

Drop & Lock Material and Finish Offerings:

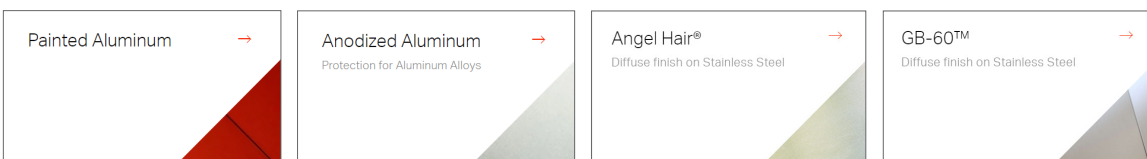

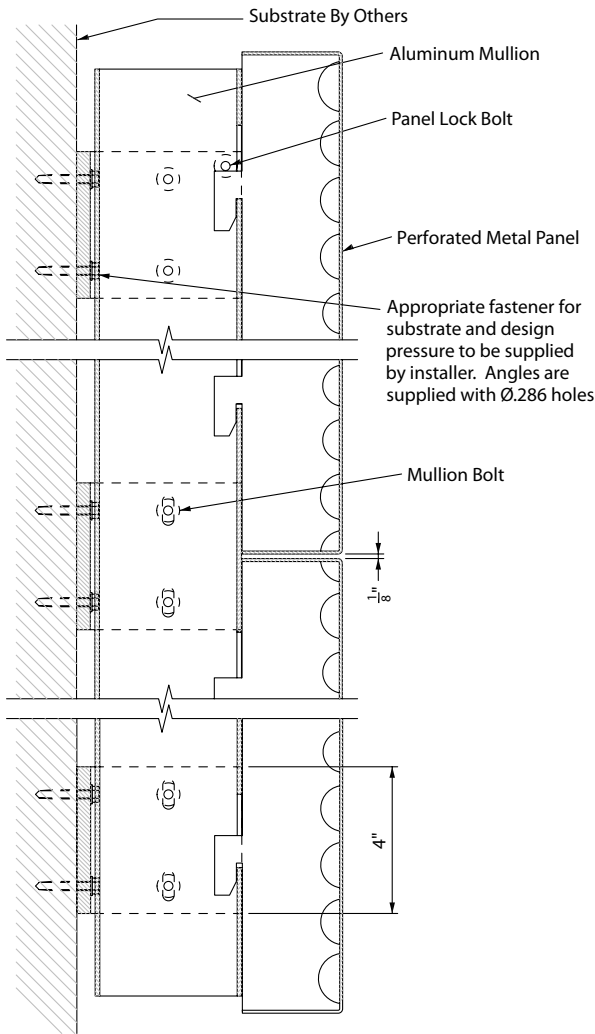

Vertical Section (A-A)

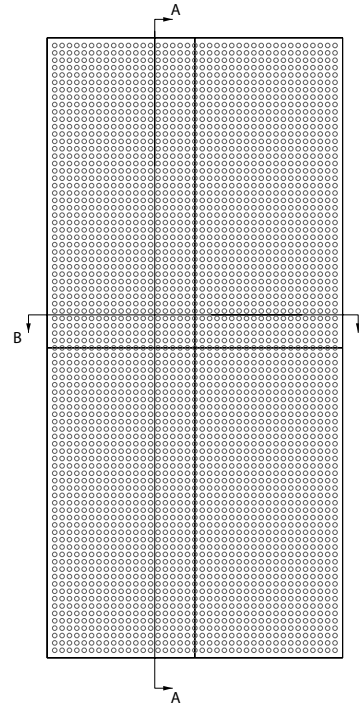

Elevation

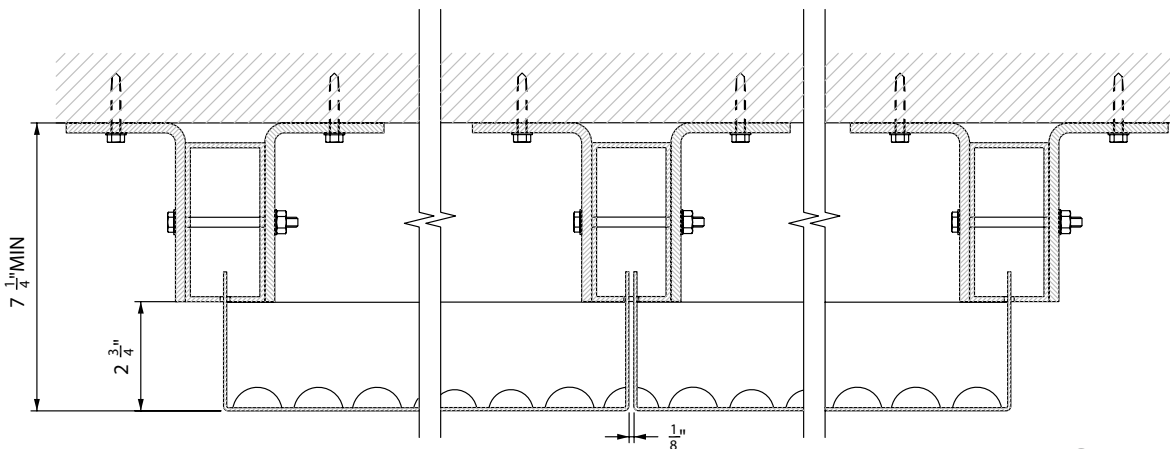

Plan Section (B-B)

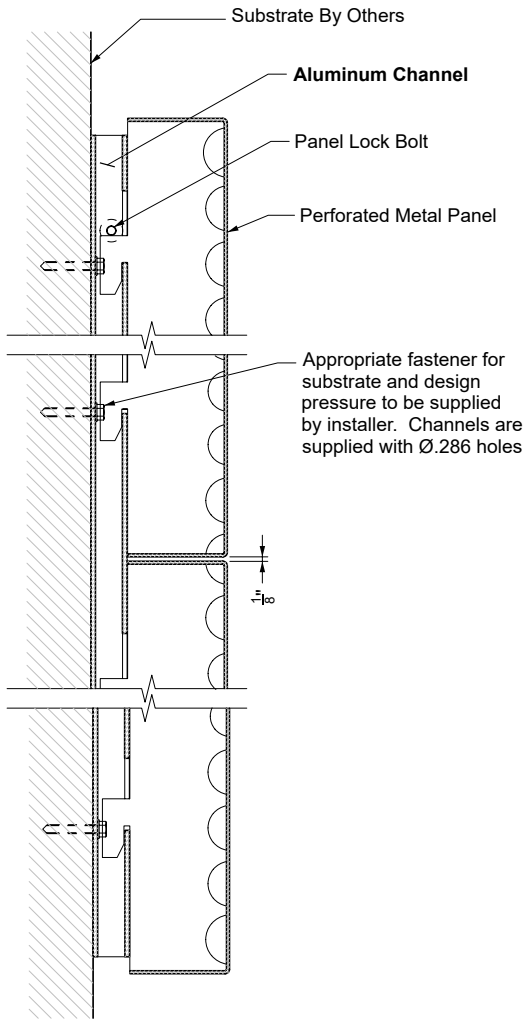

Vertical Section (A-A)

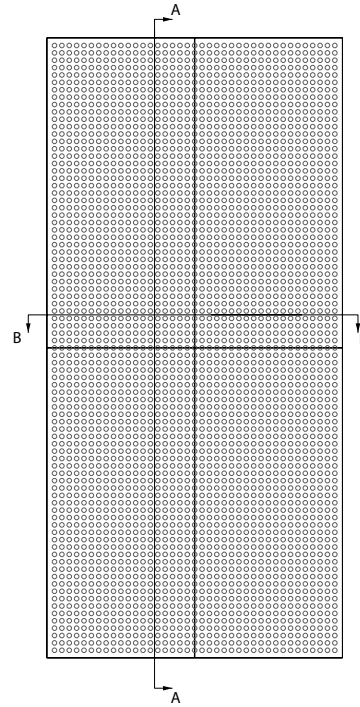

Elevation

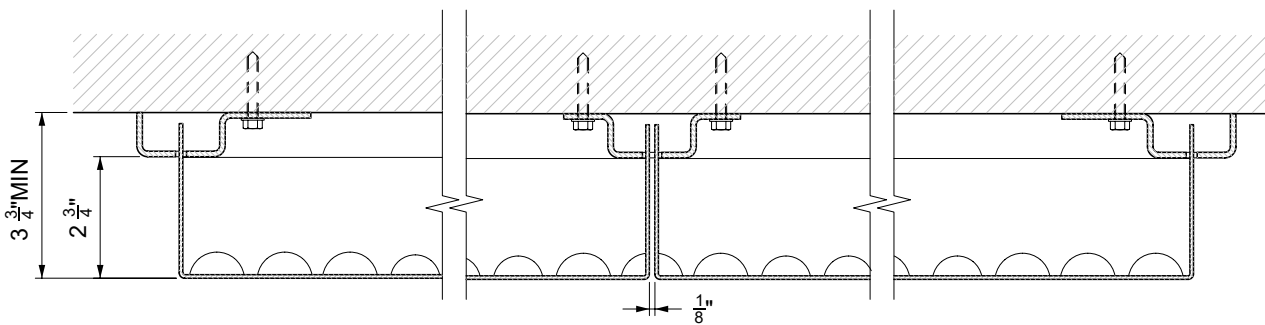

Plan Section (B-B)

The following charts are provided for preliminary design only. Please consult Zahner's licensed engineers to verify your project's specific requirements.

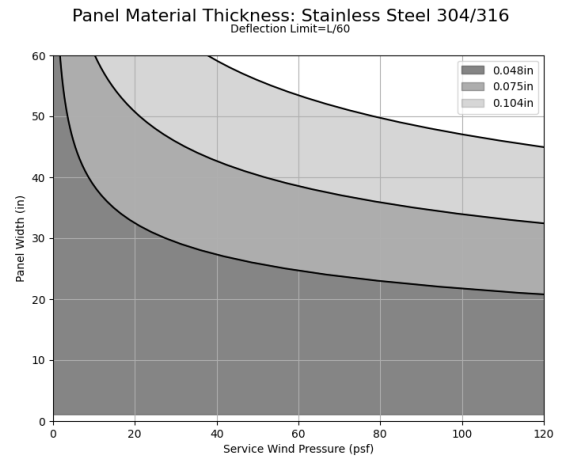
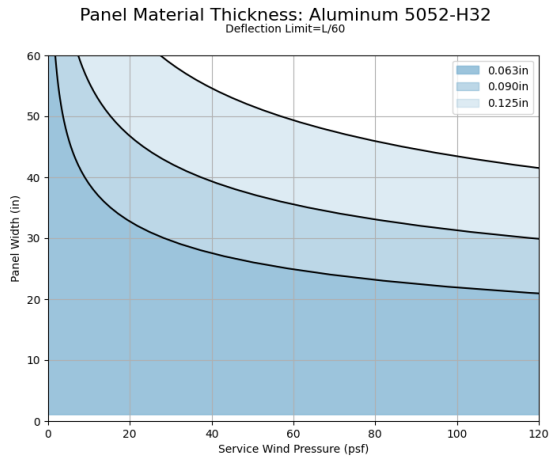

Max Vertical tube spans relative to desired pattern width and project design pressures.

